

Dragonfish Lite

Battery Quick Start Guide

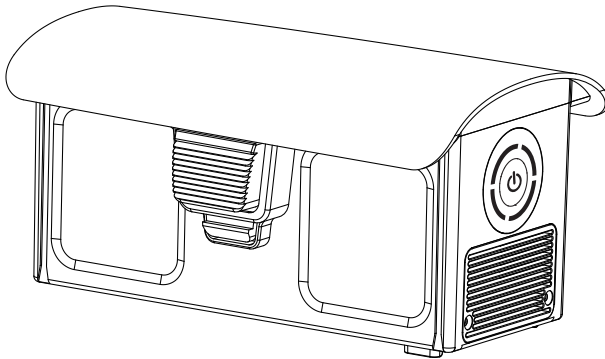

Battery safety

The Dragonfish Lite aircraft is powered by lithium-ion polymer batteries. Improper use of these batteries can be dangerous. Please ensure that the battery usage, charging, and storage guidelines are strictly followed.

Warning

- Only use the battery and charger provided by Autel Robotics. It is prohibited to modify the battery pack and its charger, or use third-party equipment to replace it.
- The electrolyte in the battery is extremely corrosive. If electrolyte splashes into your eyes or skin accidentally, immediately rinse the affected area with clean water and seek medical attention.

Battery usage

When installing or removing the aircraft battery, make sure that the aircraft is powered off. Also, pay attention to the following:

- When using the Dragonfish Lite, only use the batteries and charging devices sold or authorized by Autel Robotics. Using unapproved batteries or charging devices may cause fire, explosion, leakage or other hazards. Autel Robotic will not be held responsible for any consequences caused by the use of third-party batteries or charging devices.
- If the aircraft enters the low battery warning mode, you should land as soon as possible and stop flying, replace the battery with a new one or charge the battery.
- Do not disassemble, scratch, crush, bend, puncture, cut, twist, or intentionally damage the battery. Otherwise, this may cause fire, explosion, leakage or other hazards.
- If the battery shows signs of bulging, leakage, smoke or any other signs of damage,

stop charging or using it with immediate effect, and immerse it in a container filled with salt water.

- Please use the battery within suitable temperature (-20°C~40°C). Using the battery at excessively high or low temperature will affect the battery life. If the temperature is too high, this may result in fire or combustion. If the battery is used in excessively low temperatures, this may cause permanent damage to the battery.
- If the battery is in a low temperature range (below 10°C), the battery needs to be preheated before taking off.
- Do not use the battery in a strong static or electromagnetic environment.
- Do not expose the battery near an open flame, explosion, or other hazards.
- Do not place the battery in a microwave oven or pressure cooker.
- If the aircraft falls into the water, remove the battery immediately after recovering it. Put it in an open place and keep a safe distance from it until the battery is completely dry. After that, stop using the battery, and contact the customer service center for a replacement.
- To ensure flight safety, when the power gap between the two batteries is greater than 12%, the APP will prompt an alert and the aircraft will be restricted from taking off.

Battery charging

The Dragonfish Lite battery takes up to 120 minutes to fully charge. This may vary depending on the remaining battery power.

Also, please pay attention to the following:

- Do not use damaged battery chargers.
- When the charger is not in use, disconnect it from the aircraft battery and power supply.
- Wait for the battery to cool off at room temperature before charging. If you connect the battery to the charger immediately after flight, the temperature protection function may be automatically activated, preventing

the battery from charging until the battery is completely cooled.

Battery storage and transportation

Avoid close contact with water or heat sources when storing the battery. The battery should be stored at room temperature (ideally 22°C to 28°C (72°F to 82°F)) in a dry, well-ventilated area.

Also, pay attention to the following:

- The battery should be stored out of reach of children and pets.
- Do not store the battery in direct sunlight or near sharp objects, water, metals or re-active chemicals.
- Storing the battery in extreme temperatures will shorten its life. If the battery is not used for more than 1 day, it should be stored at a temperature of -10°C (14°F) to 30°C (86°F). Otherwise, this may result in damage or battery failure. If left unused for a long time, the battery life will be shortened.
- Do not transport damaged batteries. If the battery needs to be transported, be sure to discharge the battery to about 20%-30%.

Battery heating

In a low temperature environment (less than 10°C), short press and then long press the battery button for 5 seconds to activate the intelligent flight battery heating function, and the final battery temperature will be maintained at 15°C-20°C. The battery will hold this temperature for 20 minutes. During the heating process, short press and then long press the battery button for 5 seconds to exit the battery heating function.

Battery heating

1. Do not overcharge the battery, otherwise this may cause damage.
2. If the battery is left unused for a long period of time, its performance will be affected.

Recharge and discharge the battery every 3 months or so to maintain battery activity.

3. It is recommended that the two batteries be charged/discharged at the same time to obtain the best power supply performance. It is recommended to use the Autel Voyager pairing function and mark the paired batteries.

Battery disposal

Before disposing of the battery, be sure to fully discharge it before placing it in the designated battery recycling bin. Batteries are hazardous chemicals and are strictly prohibited to be placed in ordinary trash bins. For details, please follow local laws and regulations on battery recycling and disposal.

Aircraft battery

The Dragonfish Lite rechargeable lithium polymer battery has high energy density and a large capacity. The battery needs to be charged with the dedicated charger provided by Autel Robotics.

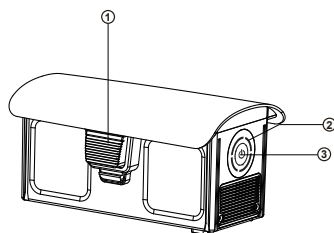

Aircraft battery

- ① Eject button
- ② Battery level indicator
- ③ Power button/battery check

Checking the battery level

With the battery off, press the power button for 1 second, and then quickly release it to check the battery level. The LED indicator will display the current battery level as shown below.

Battery level indicator status (not charging)

0%~12%



13%~25%



26%~37%



38%~50%



51%~62%



63%~75%



76%~87%



88%~100%



■ - Steady green ● - Blinking green ○ - Off

Intelligent flight battery function

The intelligent flight battery has the following functions:

- **Storage self-discharge protection**

If the battery is stored in a high temperature environment or is not used for 6 days and has a high charge, the self-discharge protection will be activated. The battery will automatically discharge to a safe level. This is the default setting, and the discharge process takes 2-3 days. Although the battery has no indication during the self-discharge cycle, you will notice that the battery slightly heats up, which is normal. The discharge threshold can be customized using Autel Voyager.

- **Low power protection**

If the battery power is low, the battery will automatically enter sleep mode to prevent over-discharge. In this mode, the battery does not respond when you press the power button. To wake up the battery, connect it to a charger.

- **Charging temperature detection**

If the temperature is lower than 5°C (41°F) or higher than 45°C (113°F) during charging, the battery will stop charging.

- **Overcurrent protection**

If the charging current exceeds 16A, the battery will stop charging.

- **Overcharge protection**

The battery stops charging automatically once fully charged.

- **Balance protection**

The voltage of each battery cell is kept balanced to prevent overcharging or over discharging.

- **Over discharge protection**

When the battery is not in use, the battery will automatically cut off the power output function after the self-discharge cycle is completed. This function is disabled during flight.

- **Short circuit protection**

Once a short circuit is detected, the power supply will be cut off.

- **Power saving mode**

If there is no operation for 30 minutes, the battery will shut down.















- **Communication**

When in use, the aircraft will maintain synchronization with the battery to provide real-time information, including voltage, capacity, current, and temperature.

- **Ultra-low energy consumption mode**

To save power, this mode will be activated when the battery is low and has not been charged for 1 day. After connecting the charger, the battery will resume normal functions.



















LED indicator warning description

LED1	LED2	LED3	LED4	Warning note
				The charging temperature is too high or too low.
				The charging current is too high and has caused a short circuit.
				Over current, overload or short circuit occurred during discharge.
 -The indicator light flashes  -Off				

Caution

If the battery overheats while charging, the LED2 indicator will flicker. If connecting to the charger, the battery will recharge automatically after the normal temperature is detected. Do not unplug the charger.

Battery level indicator status (during charging)

LED1	LED2	LED3	LED4	Battery level
				0~25%
				25~50%
				50~75%
				75~100%
 -The indicator light is always green  -The indicator light flashes green				

Specifications

Single Battery Power	174 Wh
Single Battery Charging Time	120 min
Ideal Storage Temperature	22°C to 28°C

